

SERIA X - jednostopniowe od 11 do 349 kW

23



ОДНОСТУПЕНЧАТЫЕ 1 STAGE	kcal/h		kW		⚡
	min	max	min	max	
GAS X 0	10.000	29.500	11,6	34,2	1F
GAS X 1	20.000	50.000	23,2	58	
GAS X 2	35.000	80.000	40,6	93	
GAS X 3 *	60.000	150.000	70	174	
GAS X 4 *	100.000	200.000	116	232	
GAS X 5 *	130.000	300.000	151	349	

* Имеются также в версии Low Nox
 * Available also in Low NOx version
 * wersja - uboga emisja NOx

ТЕПЛОЙ РАСХОД / РАЗМЕРЫ (мм)

FIRING RATES / OVERALL DIMENSIONS (mm)

POLE PRACY / WYMIARY (mm)

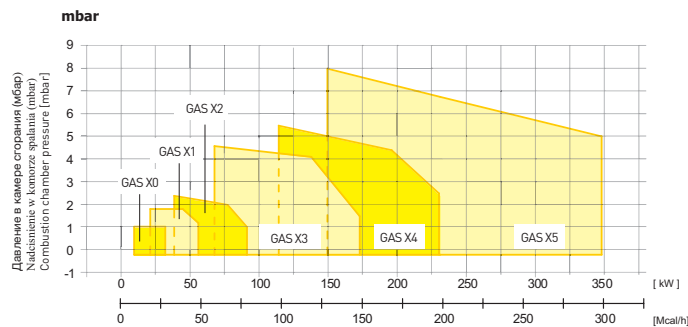
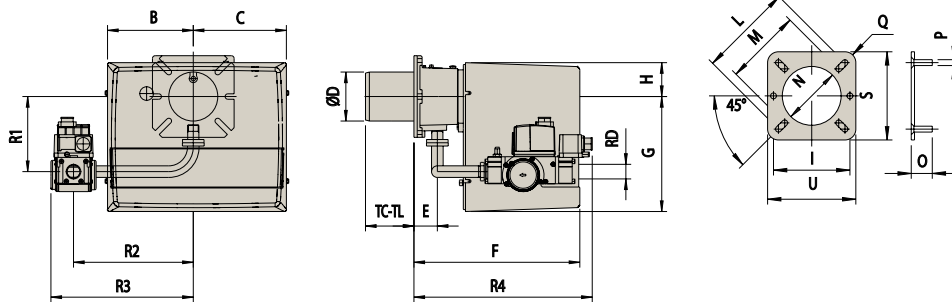

МОДЕЛЬ MODEL	B	C	ØD	E	F	G	H	I	L	M	N	O	P	Q	S	U	TC	TL	R1	R2	R3	R4	RD
GAS X0 CE - D1/2"-S	137	137	90	45	265	169	72	130	160	130	100	30	M8	R15	150	150	85	145	128	200	254	244	1/2"
GAS X1 CE - D1/2"-S	157	170	90	45	305	210	65	130	160	130	100	30	M8	R15	150	150	85	145	128	200	254	244	1/2"
GAS X2 CE - D3/4"-S	157	170	90	45	305	210	65	130	160	130	100	30	M8	R15	150	150	85	145	138	220	262	328	3/4"
GAS X3 CE - D1"-S	185	195	108	52	340	248	70	160	170	150	120	30	M8	R15	190	190	130	250	168	280	337	361	1"
GAS X4 CE - D1"-S	185	195	125	78	368	248	70	-	226	170	135	40	M10	R30	220	220	160	280	173	280	337	385	1"
GAS X5 CE - D1"-S	207	213	138	98	462	310	90	-	226	205	148	-	M10	R30	220	220	250	335	160	305	362	403	1"
GAS X5 CE - CT-D1"-S	207	213	138	98	462	310	90	-	226	205	148	-	M10	R30	220	220	250	335	160	305	480	403	1"
GAS X5 CE - D1"1/4-S	207	213	138	98	462	310	90	-	226	205	148	-	M10	R30	220	220	250	335	160	305	362	450	1"1/4
GAS X5 CE - CT-D1"1/4-S	207	213	138	98	462	310	90	-	226	205	148	-	M10	R30	220	220	250	335	160	305	480	450	1"1/4