



www.riverclack.com

 **ISCOM** SPA
METAL COVERING SOLUTIONS

via Belvedere, 7B - 37026 Pescantina (Verona) ITALY - Tel. +39 045 7732177
Fax +39 045 7732970 - www.iscom.it - iscom@iscom.it

RIVERCLACK
THE FLAT ROOF METAL COVERING SYSTEM



The flat roof metal covering RIVERCLACK® is the solution, in industrial as well as in civil building, which complies with the latest architectural trends.

Thanks to its essential shape, aesthetic, constructive economies and outstanding technical properties, RIVERCLACK® is the perfect balance between technology and appearance.

RIVERCLACK system in seven points

1 • FULL WATERPROOF

Thanks to the sealants and gaskets-free draining joint, this roof system is fully watertight even if it is submerged.

2 • PERFORATIONS-LESS LOCKING SYSTEM

Metal sheets are fixed on the below support structure without any through holes, thus allowing a free thermal expansion. Sheets more than 100 m long can be used.



3 • DURABILITY

Aluminium, copper or stainless steel sheets are unchangeable in time and have a hundred-year durability. All elements are 100% recyclable.

4 • WALK-ABILITY

It is guaranteed in every sheet area and does not leave any deflection even after several carelessness tramples.



5 • EASY INSTALLATION

Installation is quick, mark out free, and easy even for non skilled staff.

6 • COST EFFECTIVE

Long-life, no maintenance and installation quickness are the properties that make Riverclack system cost effective both for big and small works.

7 • SELF-BENDING

RIVERCLACK sheets can self curve down to a 25 m minimum radius (mill finish aluminium thickness 0.7), simply by fixing the system while following the curve shape of the below structure.

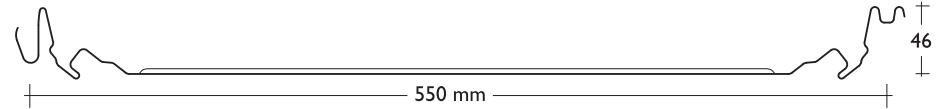

EASE OF INSTALLATION

The system is characterized by an exceptional ease of installation, with no sealants, gaskets or through perforations. Fasten system is made by reinforced polyamide brackets to be placed along each spacer. They allow free thermal movement preventing in the same time thermal bridges or electro corrosion between RIVERCLACK® and the below structure.

The system is installed using simple foot pressure onto the purpose designed polyamide bracket fixed to the spacer by two screws.



RIVERCLACK sheet installation in 6 steps.



FULL RELIABILITY



FULL RELIABILITY

RIVERCLACK® is an exclusive flat roof covering system - result of a ten-year research and testing - worldwide patented by ISCOM SPA. Each detail has been optimized for its own function and its technical characteristics make it unique. RIVERCLACK® boasts millions of square metres in service throughout the world meeting the full customer and designer satisfaction.

The drainage channel system: a guarantee of full waterproofing. The first cone-shaped protection - in case of completely flooded roofs - lets pass through much less water than the inside duct is able to drain.

The drainage channel shape is a rising section pipeline allowing a growing water flow proportional to the water level increase.

When the roof is entirely flooded, the inside duct holds much less water than it could be able to contain. Therefore, water is easily drained to gutter. The sheets joint solution is sealants or gaskets-free. RIVERCLACK® striated flat area is really appreciated not only for its stiffening function, but also for its look.

The reinforced polyamide locking system lets RIVERCLACK® sheets be free to slide longitudinally without any abrasions and, at the same time, it guarantees heat and electric proofing between roof and the below support structure.

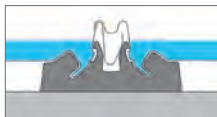

Frequent cases of reliability drop instances in traditional metal roofs avoidable with the use of RIVERCLACK®.

- Fixing holes out-of-roundness due to thermal movements
- Screws pulling up or buckling
- Surface tearing
- Perforation due to physical-chemical deterioration.

COMMON RISKS

- Driving rain
- Heavy rain and strong wind
- Heavy rain and hail
- Snow
- Inadequate slope

RIVERCLACK® System overcomes the reliability drop being designed to excel in extreme limit conditions without maintenance.



RELIABILITY UNDER USE CONDITIONS

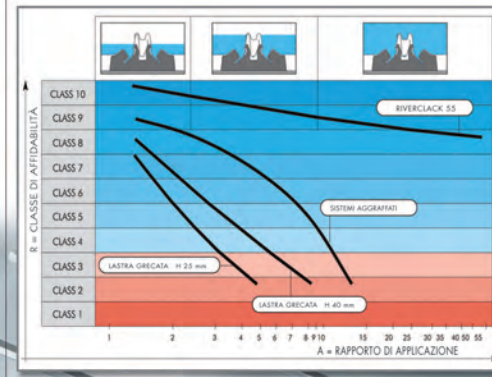

Reliability is the first requirement for a good roof. The best and long lasting results can be achieved only with RIVERCLACK®.

As a matter of fact, RIVERCLACK® is the only system able to achieve a reliability class never lower than 8 to any length and pitch of the sheets. Traditional steel decks need around 3500 through perforations each 1000 square metre being this a high risk factor for the waterproofing. No other standing seam system can assure waterproofing when the roof is totally flooded.

$$A = \frac{L}{P}$$

L = pitch length (metres)
P = pitch slope (%)
R = reliability class
A = use ratio

MEANING OF RELIABILITY CLASS

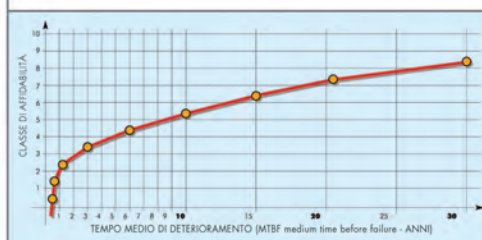

I valori sopra riportati sono dati statistici e dipendono da anni di esperienza e da molteplici condizioni, quali: TIPO DI SOVRAPPONIZIONE • CAPACITÀ IDEALICA DEGLI ELEMENTI • CURA NELL'INSTALLAZIONE • ESPERIENZA SUL SISTEMA

RIVERCLACK®

- Perfect waterproof joints without any through perforation
- Sheets shape with the maximum hydraulic capacity
- Easy installation
- Proven system with millions square metres installed in tens of years in Italy and in the World

RIVERCLACK® WHEN?

- Always, if you need a high reliability
- Always with a use ratio A (length/slope) >2



LOAD TABLE		DISTRIBUTED LOAD KN/m ²					
		FREE SPAN (cm)	100	120	140	160	180
MILL FINISH ALUMINIUM Alloy 5754	thickness (mm)	0,7	6,51	3,77	2,39	1,65	1,16
		0,8	7,44	4,30	2,37	1,88	1,32
		1,0	9,30	5,38	3,42	2,35	1,65
PRE-PAINTED ALUMINIUM Alloy 5754	thickness (mm)	0,7	6,32	3,66	2,33	1,60	1,12
		0,8	7,22	4,18	2,66	1,83	1,28
		1,0	9,03	5,23	3,32	2,29	1,61
COPPER	thickness (mm)	0,6	9,56	5,53	3,52	2,42	1,70
		0,7	11,16	6,46	4,10	2,82	1,98
		0,8	12,75	7,38	4,69	3,23	2,27
STAINLESS STEEL	thickness (mm)	0,5	6,50	4,51	3,32	2,54	2,01
		0,6	7,77	5,40	3,96	3,04	2,40
		0,7	9,06	6,29	4,62	3,54	2,80
PRE-PAINTED GALVANIZED STEEL	thickness (mm)	0,5	5,93	4,12	3,02	2,32	1,83
		0,6	7,09	4,92	3,62	2,77	2,19
		0,7	8,27	5,74	4,22	3,23	2,55
ZINC/TITANIUM ALLOY	thickness (mm)	0,8	6,31	4,38	3,22	2,29	1,61
		1,0	7,88	5,47	4,02	2,86	2,01

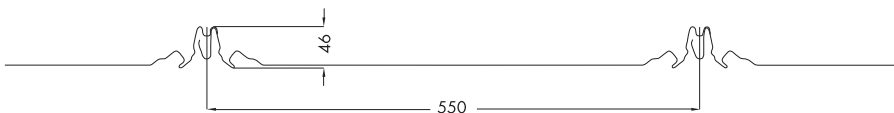
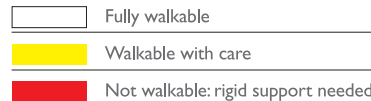
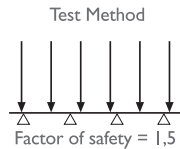

WALK-ABILITY

Load tests have been carried out on a 0.7 mm thick aluminium RIVERCLACK® sheet using a rubber-clad piston designed to simulate human foot traffic.

Both dynamic and static-dynamic tests have demonstrated product high performances. RIVERCLACK® roof system can be safely and fully walked up and down.



WATERPROOFING

The test has been carried on 19.50 m long 0.7 mm thick aluminium sheets laid down with a 0.3 % slope; using the sheets as the base of a pool filled with water, after 45 days, only a few drips have been detected from the draining joint. No leaks in roof intrados have been found; moreover, also bottom was entirely dry. Therefore, RIVERCLACK® system guarantees full waterproofing.



WIND SUCTION LOAD RESISTANCE

Wind resistance test has been performed on 0.7 mm thick aluminium sheets and at 1200 mm span.

A purpose designed plastic airbag has been progressively inflated under the sheets to generate an underneath pressure and simulate the effects of a wind vortex passing over the roof, till to requested loads. The achieved results are the demonstration of the roof system excellent performances, even in strong gusts of wind, till more than 7,00 KN/m².

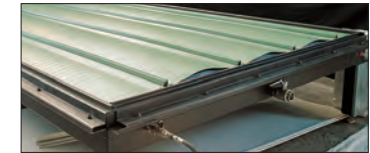

RIVERCLACK System is certified by the major international certification Institutes.



In the United Kingdom for material manufactured and distributed by CA GROUP with the trademark River-Therm



CURVING

RIVERCLACK® sheets are extremely flexible. They are self-bending on convex, concave and S shapes, depending on material and thickness used, according to the below table:

SELF BENDING PARAMETRES				
CONCAVE CURVING	Aluminium 0,7 mm	Aluminium 0,8 mm	Copper 0,6 mm	Zinc-Titanium alloy
Self-Bending R min (mm)	30000	30000	36000	25000
CONVEX CURVED	Aluminium 0,7 mm	Aluminium 0,8 mm	Copper 0,6 mm	Zinc-Titanium alloy
Self-Bending R min (mm)	25000	25000	30000	20000

Beyond the above-cited limits, sheets must be mechanically curved.



MACHINE CURVING

Machine curving is available to make RIVERCLACK® meet the nowadays architectural trends of convex, concave and S shapes, keeping constant and unaltered its highest standards of reliability and long life.

The machine curving process can be carried out in the factory as well as on site thus allowing to curve, partially or in total, long sheets.

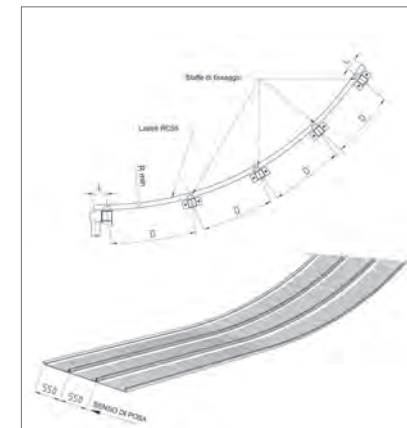
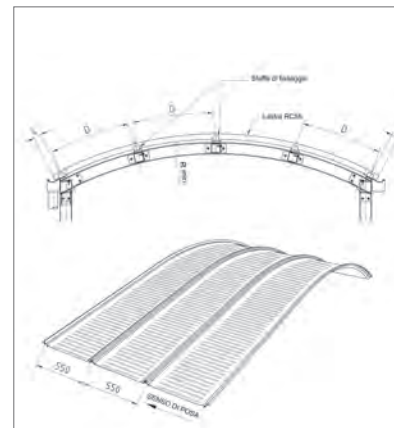

Machine curving limitations according to different materials and thickness are described in the below table:

MACHINE CURVING PARAMETRES				
CONCAVE CURVING	Aluminium 0,7 mm	Aluminium 0,8 mm	Copper 0,6 mm	Zinc/Titanium alloy
Made by curving machine R min (mm)	10000	8000	16000	10000
CONVEX CURVING	Aluminium 0,7 mm	Aluminium 0,8 mm	Copper 0,6 mm	Zinc/Titanium alloy
Made by curving machine R min (mm)	4000	3000	6000	3000

DOUBLE CURVING

The so-called double curving occurs when spherical and hemispherical structures need to be covered; it also involves structures which have been planned curved both in the direction of the sheet axis and in its normal direction. It appears also in case of a curving together with the need of tapering.

In order to accommodate this, besides the development of suitable analysis software, Iscom has designed a special friction-proof bracket in-width adjustable, capable of absorbing the differences resulting between one sheet and the next. It is always advisable to contact Iscom technical offices to perform the feasibility analysis of these applications.

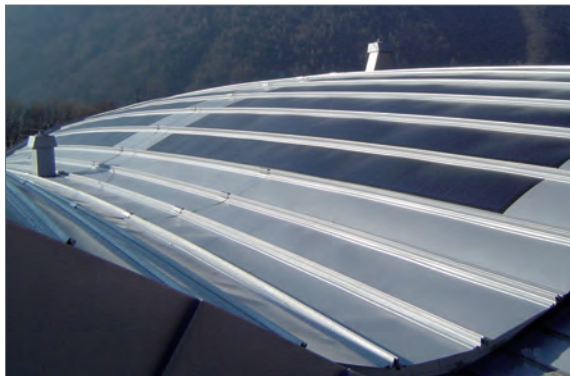
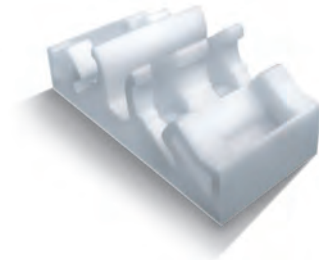

TAPERED SHEETS



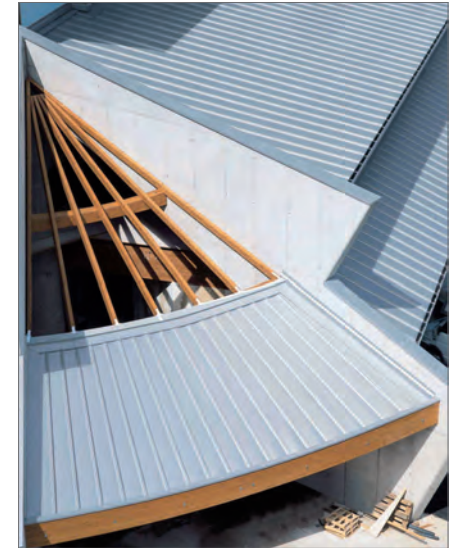
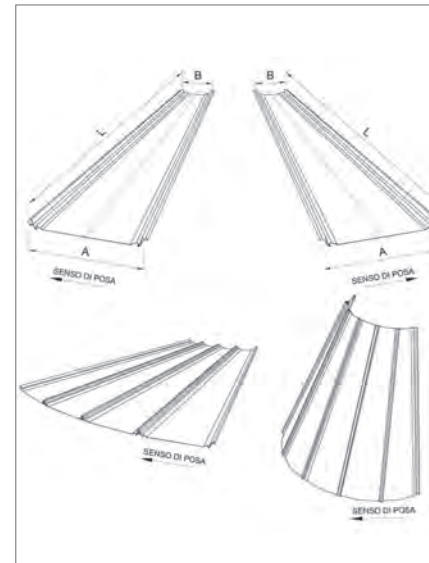

RIVERCLACK® new generation rolling mills can be equipped with a special kit which allows to produce tapered or custom width panels in order to comply with conic or "fan" shaped roof geometries



HIGH SEAM - RIVERCLACK 50

In case of large span distance, ISCOM can provide a special version of the Riverclack profile: Riverclack 50
The high seam profile RIVERCLACK 50, being characterized by a rib's high of 70mm instead of 46mm, allows to span up to more than 2 metres, keeping unchanged all the typical features of RIVERCLACK® such as fixing system, drainage channel, custom lengths and improving both the mechanical performance and the hydraulic capacity of the profile.

DISTRIBUTED LOAD KN/m²

FREE SPAN (cm)		140	160	180	220	260	
 MILL FINISH ALUMINIUM Alloy 5754	thickness (mm)	0,8	9,22	7,06	5,58	3,11	1,89
		1,0	11,52	8,82	6,97	3,90	2,36
 PRE-PAINTED ALUMINIUM Alloy 5754	thickness (mm)	0,8	8,06	6,17	4,88	3,02	1,83
		1,0	10,07	7,71	6,09	3,79	2,30
 COPPER	thickness (mm)	0,7	12,01	9,19	7,26	4,66	2,82
		0,8	13,74	10,52	8,31	5,34	3,23
 STAINLESS STEEL	thickness (mm)	0,6	7,78	5,96	4,71	3,15	2,26
		0,7	9,01	6,89	5,45	3,65	2,61
		0,8	10,30	7,89	6,23	4,17	2,99
		1,0	12,87	9,86	7,79	5,21	3,73
 PRE-PAINTED GALVANIZED STEEL	thickness (mm)	0,6	7,10	5,44	4,30	2,88	2,06
		0,7	8,22	6,29	4,97	3,33	2,38
		0,8	9,40	7,20	5,69	3,81	2,73
		1,0	11,74	8,99	7,10	4,76	3,41

Test Method

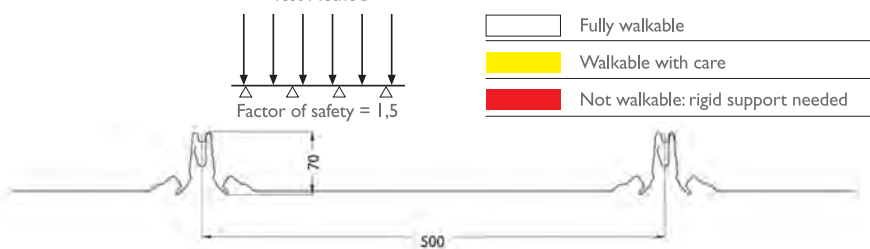

Riverclack 55 and Rivergrip BENDED SHEETS

A robust detailing is very important for the reliability of a roof.

Whatever the length it is possible to bend or bend and cut the metal sheets lengthwise, in order to solve at the best the roof verge details, especially in cases of low slopes and risks of roof submersion.

The bends can be made both upward and downward, this last for aesthetic reasons when the continuity between roof and facade is wanted.

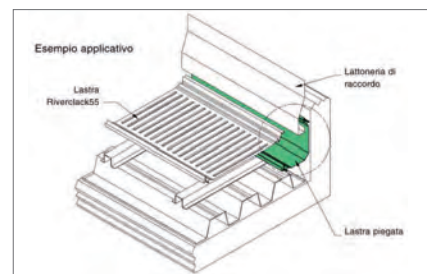
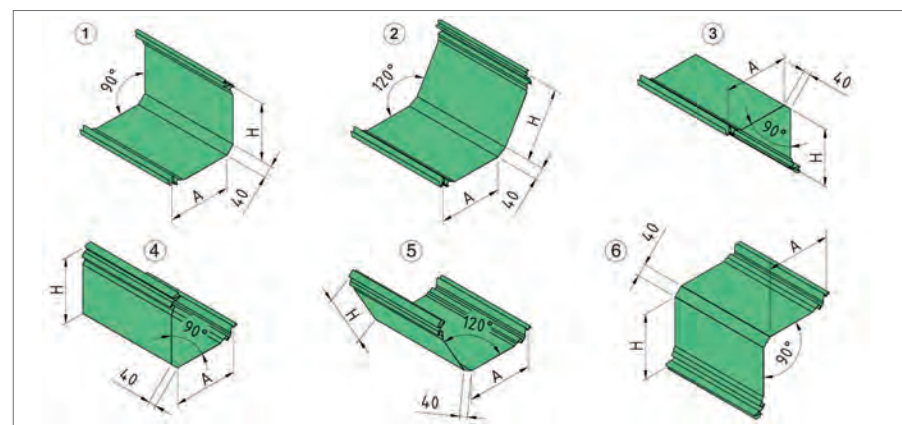

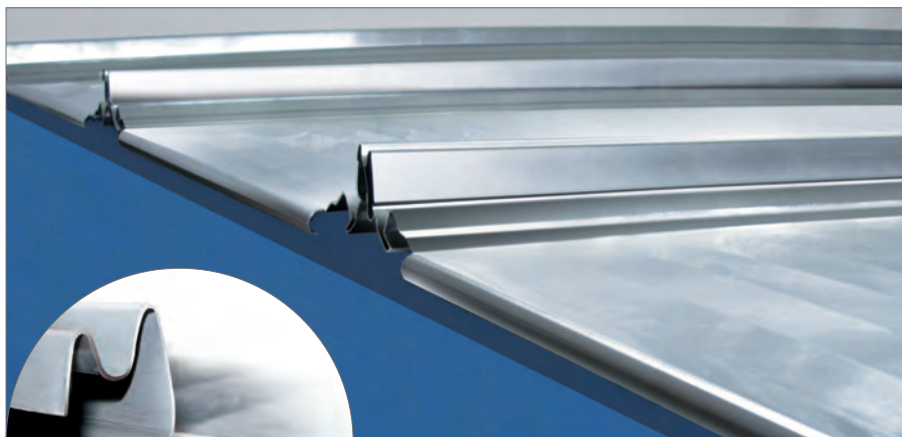

“TORO” END LAP

The sheets end lap, renewed and improved with the so called “Toro” add some extra features to the RIVERCLACK® system:

- It strengthens the “gutter side lap” of the sheet
- It helps the drainage, avoiding risks of water dripping outside the gutter.
- It confers a high aesthetic value, enhancing sheets final section.
- It avoids the manual bending of the sheets end lap during the installation phase, which is required for slopes lower than 5%.

“Toro” end lap is for both sheet’s ends, bringing the following advantages:

- Possibility to employ the RIVERCLACK® system on roofs from gutter to gutter with the same features in both terminals.
- No constraints as for direction of installation.
- Improved ridge detailing thanks to the strenghtening of the end lap.

The “Toro” is available only for RIVERCLACK® 55 sheets.

In any case “Toro” is not available for tapered, curved and bended sheets.

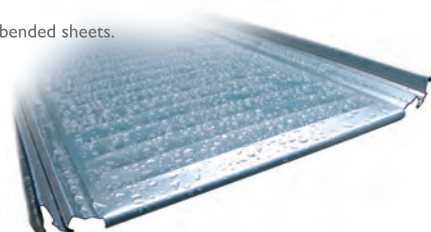

EXCEPTIONAL TRANSPORTS, ON SITE PRODUCTION AND UPLIFT

Iscom provides the costumer with the maximum support in order to help them in the use of its innovative products. For this reason, ISCOM is at their disposal for the organization of exceptional transports of long sheets to the building site.

In case of sheets exceeding the maximum transportable length, Iscom can organize the production directly on the building site.



The rolling mill is the fully engineered, factory specification production unit (manufactured by ISCOM) which is compact enough to be easily transported by lorry in order to facilitate on-site rolling.

This allows to produce sheet lengths with no limits, to remove the need for end-laps on long slopes, meeting both the aesthetical and functional demand.

Iscom also offers its experience and professional competence for the lifting up of the long sheets.

For this operation, several modular lifting beams for sheets up to 90 m. long, are available. If necessary or convenient, gradient ramps may be designed and made, allowing the forming machine to push the sheets onto the roof .



RIVERCLACK METALS

The high RIVERCLACK® demanded performance has taken to the necessary choice of long-life and strong environment-against (such as acid rains, industrial pollution, etc.) materials. Aluminium, copper and stainless steel are the system safety and reliability warranty, showing up its structural performances.

GALVANIC BEHAVIOURS

As everybody knows, it is advisable to avoid contacts between different metals in order to prevent electrochemical corrosions (galvanic couple). With the RIVERCLACK® system, stainless steel accessories can be used for elements in aluminium or copper without any compatibility problem between different metals.

DIFFERENCE BETWEEN ALLOYS 5000 AND ALLOYS 3000.

Aluminium alloy 5754 used for RIVERCLACK® has got mechanical and chemical characteristics far above the normal alloys 3000 used generally for metal roofing. The use of alloy 5754 is advised in the UNI 10372 norm, related to metal roofing design, for the use in marine as well as in industrial environments, rather than other alloys. The high hardening degree (H18), together with other features of the alloy 5754, with high magnesium content, used for RIVERCLACK® system, represent the right choice to have a light and resistant roof covering

Thickness loss in microns

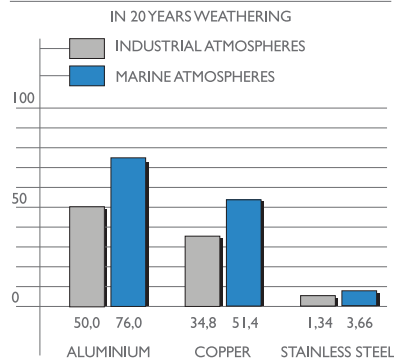

ALUMINIUM ALLOY 5754

Light, best relation between durability and cost, it is the best acid rain-proof. It is used in the physical state H18/19 which grants an extraordinary mechanic resistance to the metal



PRE-PAINTED ALUMINIUM ALLOY 5754

In addition to the own features of the metal, pre-painting adds aesthetics specification following the architectural needs

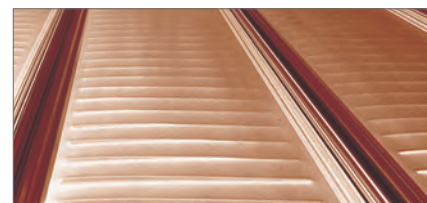

COPPER

It is a noble metal, with a unique reflection feature and it is the typical answer for any aesthetic



ZINC TITANIUM

Prestigious material whose surface aesthetic value is given by the natural shade change. The metal mechanical features require a rigid back support.

MATERIAL ALLOY	ALUMINIUM Alloy 5754 H18	COPPER Cu-DHP UNI 5649 raw	TITAN ZINC	STAINLESS STEEL UNI x 5 Cr NI 18 10-AISI 304	GALVANIZED STEEL
DENSITY g/cm³	2,72	8,9	7,2	8,06	8,06
MELTING POINT °C	650 ~	1080 ~	418	1450 ~	1450 ~
COEFFICIENT OF EXPANSION mm/m°C	0,0240	0,0173	0,0220	0,0141	0,0141
ELASTIC MODULUS kg f/mm2	6500	12000/13500	8000	19700	19700
ELOGATION%	5 ~	2 ~	40 ~	40 ~	40 ~
TENSILE STRENGTH N /mm2	300 ~	400 ~	210	550/700	550/700
BRINNEL HARDNESS HB	90	120	40	150	150

Type of hardening	grade	Element in alloy	Content (in %)	Additional element	Strenght Rm (in MPa) up to
Hardening by plastic deformation	1000	Nothing		Cu	160
	3000	Manganese	0,5 a 1,5	Mg, Cu	240
	5000	Magnesium	0,5 a 5	Mn, Cr	350
	8000	Ferro e Silicio	Si: 0,3 a 1 Fe: 0,6 a 2		190

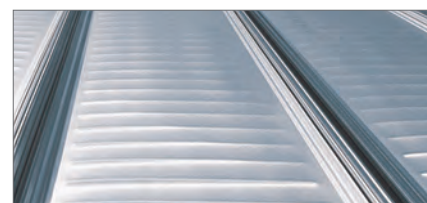

STAINLESS STEEL

It is an unchangeable material, it does not thin in time

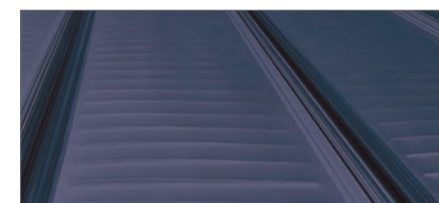

PRE-PAINTED GALVANIZED STEEL

In addition to the own features of the metal, pre-painting adds aesthetics specification following the architectural needs

COLOURS AND FINISHINGS

Riverclack system offers a wide range of colours and finishings as also texturized in copper-like or zinc-like coatings. The charts of available colors are reported as follows. Polyester, PVDF and polyamide paint can be offered in one or more layers.

Different finishings are available, according to the metal used, and some of them can add valuable aesthetic features. Worth mentioning is the embossing, which is very useful on natural aluminum to diminish light reflection and consequent glares (airports or buildings near roads and highways).

For particular situations, perforated materials can be used (shadings or acoustically insulated walls). Aluminum can be anodized with various finishing for elements of great value. Copper may be pre-oxidized, in several finishing ranging from green to dark brown.

Zinc is always pre-oxidized, but it may be supplied either in dark or light shade.



BASIC RANGE (GLOSS 20/30)

Dark brown
RAL n.d.
Testa di moro



Pale green
RAL 6021
RGB 133 166 122



Grey white
RAL 9002
RGB 240 237 230



SILVER RANGE (GLOSS 20)

White aluminium (Silver)
RAL 9006



TREND RANGE (GLOSS 20/50)

Oxide red
RAL 3009
RGB 94 33 33



Pastel blue
RAL 5024
RGB 87 140 171



Anthracite grey
RAL 7016
RGB 38 46 56



Dusty grey
RAL 7037
RGB 122 125 128



EXCEL RANGE (GLOSS 40/50)

Oyster white
RAL 1013
RGB 255 245 227



Light ivory
RAL 1015
RGB 252 235 204



Zinc yellow
RAL 1018
RGB 255 214 77



Rape yellow
RAL 1021
RGB 252 189 31



Melon yellow
RAL 1028
RGB 255 140 26



Red orange
RAL 2001
RGB 186 46 33



Gray blue
RAL 5008
RGB 26 41 56



Steel blue
RAL 5011
RGB 0 43 112



Light blue
RAL 5012
RGB 41 115 186



Sky blue
RAL 5015
RGB 23 97 171



Night blue
RAL 5022
RGB 0 8 79



Distant blue
RAL 5023
RGB 46 82 143



Leaf green
RAL 6002
RGB 38 87 33



Blue green
RAL 6004
RGB 13 59 46



Moss green
RAL 6005
RGB 10 56 31



May green
RAL 6018
RGB 79 168 51



Chrome green
RAL 6020
RGB 38 56 41



Opal green
RAL 6026
RGB 10 92 51



Mint green
RAL 6026
RGB 18 120 38



Slate grey
RAL 7015
RGB 61 66 82



Pebble grey
RAL 7032
RGB 189 186 171



Light grey
RAL 7035
RGB 212 217 219



Platinum grey
RAL 7036
RGB 158 150 156



Window grey
RAL 7040
RGB 158 163 176



Traffic grey A
RAL 7042
RGB 143 150 153



Telegrey 4
RAL 7047
RGB 217 214 219



Copper brown
RAL 8004
RGB 133 56 43



Sepia brown
RAL 8014
RGB 56 38 28



Grey brown
RAL 8019
RGB 40 38 41



Cream
RAL 9001
RGB 252 252 240



Pure white
RAL 9010
RGB 250 255 255



Graphite black
RAL 9011
RGB 13 18 26



Traffic white
RAL 9016
RGB 252 255 255



Papirus white
RAL 9018
RGB 219 227 222

